



# Use of Solar Power in Agriculture and Agro Processing Industries



**State Planning Commission**  
**05-09-2013**

# Use of Solar Power in Agriculture and Agro Processing Industries



**State Planning Commission**  
**05-09-2013**



## Tamil Nadu State Planning Commission

The State Planning Commission was constituted in Tamil Nadu on 25th May 1971 under the Chairmanship of the Hon'ble Chief Minister as an Advisory body to make recommendations to the Government on various matters pertaining to the development of the State. The Chairman of the Commission is assisted by a team of Members, Consisting of Vice Chairman, Full Time Member & Part Time Members who are experts in various fields. The Principal Secretary to Government, Planning, Development and Special Initiatives and the Principal Secretary to Government, Finance Department are the ex-officio members. The Member Secretary is responsible for administration in the Commission.

### The Commission has the following technical divisions:

1. Agricultural Policy and Planning
2. Industries, Power and Transport
3. Land Use
4. Education and Employment
5. Health and Social Welfare
6. District Planning and Rural Development
7. Plan Co-ordination.

### Main activities of SPC:

The major functions of the State Planning Commission are as follows:

1. Preparation of Five Year and Annual Plans based on the policies and priorities of the Government;
2. Undertake Mid Term review of the Five Year Plan, other special reviews on the Economy and advise the Government on appropriate modification and restructuring of the schemes;
3. Monitor development indicators that influence the Human Development Index, Gender Development Index, etc., at a disaggregated level and suggest correctional measures;
4. Undertake special studies as required for formulation and implementation of plan projects and programmes;
5. Tamil Nadu State Land Use Research Board (TNSLURB) is functioning under the chairmanship of Vice Chairman, State Planning Commission as a permanent body in the State Planning Commission. This Board is intended to promote interaction and study in the vital areas of land use. The State Planning Commission organizes seminars/workshops and undertake studies.
6. Human Development Reports (HDRs) were prepared for Dindigul, Sivagangai, Tiruvannamalai, Cuddalore, Nagapattinam, the Nilgiris, Kanyakumari and Dharmapuri districts. The concept of Human Development has been disseminated to all districts through workshops organized in the concerned districts. Proposal for preparation of District Human Development Reports (DHDR) for the remaining districts is under process.
7. State Balanced Growth Fund (SBGF) is operated to bridge the regional imbalances among the districts.

| Details   | Page No. |
|---|----------|
| Workshop Team   | 4        |
| Workshop Sessions   | 5        |
| Executive Summary   | 6        |
| Introduction  | 8        |
| Sessions  |          |
| <b>Session I</b><br>Designing of Solar Water Pumps for Farms                |          |
| <b>Session II</b><br>Benefits of Solar Water Pumps in Agriculture           |          |
| <b>Session III</b><br>Solar Energy in Agriculture and Allied sectors        |          |
| <b>Session IV</b><br>Application of Solar Energy in Post harvest Management |          |
| <b>Session V</b><br>Use of Solar Energy for Agro Processing                 |          |
| Recommendations   |          |
| List of Participants  |          |

## State Planning Commission

***Tmt. Santha Sheela Nair, IAS.,(Retd.)***

Vice Chairperson

***Thiru M. Balaji, IAS.***

Member-Secretary

***Tmt. D.S. Bharathi,***

Head of Division

Industries, Power and Transport Division

***Tmt. P. Ruth Pramila,***

Planning Officer

Industries, Power and Transport Division

***Thiru S. Boopathy Mohan***

Programmer

***Thiru A. Ramaiah***

Technical Assistant

Industries, Power and Transport Division

***Thiru Vineeth Vijayaraghavan***

Founder, Panchabuta-Renewable Energy and Cleantech, Chennai

|  |   |
|--|---|
| Welcome Address  | <b>Thiru M.Balaji, I.A.S.</b><br>Member Secretary<br>State Planning Commission.                             |
| Inaugural Address  | <b>Tmt. Santha Sheela Nair, IAS.,(Retd.)</b><br>Vice-Chairperson<br>State Planning Commission               |
| <b>Session I</b><br>Designing of Solar water Pumps for Farms                   | <b>Mr. Ravi Karamcheti,</b><br>Managing Director, Solar Water Pumps,<br>Sun Edison India                    |
| <b>Session II</b><br>Benefits of Solar Water Pumps in<br>Agriculture           | <b>Mr. Rangarajan Ramaswamy,</b><br>Director, Service and Training, GrundfosPumps<br>India Pvt Ltd, Chennai |
| <b>Session III</b><br>Solar Energy in Agriculture and Allied<br>sectors        | <b>Mr. Ravikumar Kandasamy,</b><br>Mahatma Gandhi Institute for Rural<br>Industrialisation, Govt. Of India. |
| <b>Session IV</b><br>Application of Solar Energy in Post harvest<br>Management | <b>Dr. Kamaraj,</b><br>Professor and Head,<br>Post Harvest Technology Centre, TNAU ,<br>Coimbatore          |
| <b>Session V</b><br>Use of Solar Energy for Agro Processing                    | Tamil Nadu Energy Development Agency<br>(TEDA)  |
| Round Table Discussion & Concluding Remarks                                    | <b>Tmt. Santha Sheela Nair, I.A.S .,(Retd),</b><br>Vice Chairperson , State Planning Commission             |

State Planning Commission organized a workshop on “Use of Solar Power in Agriculture and Agro Processing Industries”. Energy is the major source for the development of agriculture and industry. Tamil Nadu receives very high solar radiation which indicates a very clear potential for solar based power generation. Hence, solar energy is a highly desirable renewable energy source that has immense potential in agriculture and agro-processing industry.

Energy is one of the major parameters for establishing growth and progress of the country, rather, the standard of living depends directly upon the per capita energy consumption. To effectively meet the power requirements, to enhance industrial growth and economic development, solar energy is a viable option when adopted on a large scale. Low environmental externalities, low social displacement, energy security and national security implications, zero emissions during operation the advantages for harnessing solar power. The Government of Tamil Nadu is committed to promote renewable energy generation in the State and has come out with “Tamil Nadu Solar Energy Policy – 2012” which aims at generating 3000 MW of solar power by 2015 with a vision of developing the State as a world leader in Solar Energy.

The first session focussed on ‘Designing of Solar water Pumps for farms’. Agricultural farming, processing and storage have high and variable energy needs. In this session, Mr. Ravi Karamcheti, Managing Director, Solar Water Pumps, Sun Edison India highlighted on the use of the solar powered pumps for farming activity in the state. It has become easier and more

affordable to use solar power on a farm due to the rapid advancements in technology and the increasing awareness about renewable energy sources. Solar Water Pumps will directly impact agriculture through improving the yield of per unit of land/ water and accelerating innovation and extension mechanism and ensure timely irrigation was discussed. Promoting efficient use of water by modernization of irrigation systems and improved service delivery, participation of farmers and popularization of micro irrigation was discussed. A description of Solar water pump system and its components was given in this session. High efficiency Photo Voltaic modules generate power which helps high efficiency 3-phase AC pump to deliver water from source. Solar water pumps creates a difference in irrigation farmers by enhancing the customer value proposition by providing an alternative for intermittent grid power which enables to do day time irrigation.

Mr. Rangarajan Ramaswamy, Director, Service and Training, Grundfos Pumps India Pvt. Ltd, Chennai presented on the benefits of solar water pumps in Agriculture. Solar water pumps helps the farmers and results in lower Pump Failure rate and less maintenance and higher agricultural yield.

The presentation by Mr. Ravikumar Kandasamy, of Mahatma Gandhi Institute of Rural Industrialisation highlighted the energy conservation and the green practices for agriculture through use of the solar power. It stressed on the innovative green initiatives available in the agro-industries through renewable energy mainly through solar energy. Agro-Industries may differ from the large Industries in scale or in different aspects



but energy, is the prime necessity which is not fully available in rural sector and for SME's. Rural industries (specifically Micro & Small industries) have the advantage of being small and also get the energy needs through renewable energies or energy conservation through locally available resources, redesign of the existing systems, and innovations. Solar Applications in cotton to garment processing is highly effective since it is possible to promote the decentralized solar applications through segmenting the textile process machineries

The use of solar energy in various applications commonly used, presented in this session were Solar Cotton to Garment Business Unit, Solar Charkhas implemented all over India in Khadi Sector, Mini Solar Spinning Unit and Solar Powered Power-loom in Tirupur & Auroville in Tamil Nadu. The new DC Drive system coupled to the same power loom consumes about 300 Watts of Power thereby resulting in power savings of more than 50%. The locally available renewable energy resources helps in providing sustainable employment throughout the year.

The use of solar powered machines for agricultural processing. Viz solar fodder machine, solar fruit grader, etc. Solar power is used by artisans in solar micro tools, solar potter wheel, energy efficient potter kiln etc was also presented. The use of solar energy for varied activities not village were also presented in this session .

Dr.S.Kamaraj, Professor and Head, Dept of Bio energy, Tamil Nadu Agricultural University, highlighted on the use of this source of energy for varied agricultural activities. The solar energy incident over India is 4-7 KWh/

m<sup>2</sup> . As per the Solar Policy Tamil Nadu 2012, all new Government buildings need to have solar roof tops and all existing Government buildings to install Solar Roof Top systems. All domestic consumers installing Roof Top Solar systems will be provided Generation Based Incentives (GBI) for Solar Power Plants and Wind – Solar Hybrid Systems as Rs.2 per unit for first 2 years, Re.1 for the next two years and Rs.0.50 for the subsequent two years. Solar fencing consisting of solar panel, energiser, battery and fencing system helps to protect the crops from forest animals.

Solar Thermal applications is used in solar cookers, solar water heaters, solar tunnel dyers, solar distillation and solar ponds. Commercial dairy farms use large amounts of energy to heat water that is used to clean equipment. Solar water heating systems may be used to supply all or part of these hot water requirements. Sophisticated solar dryers can protect grain and fruit, reduce losses, dry faster and more uniformly, and produce a better quality product than open-air methods. With proper planning and design, solar air heaters can be incorporated into farm buildings to preheat incoming fresh air.

Renewable energy forms a major source of energy, of which solar energy, harnessed from the sun, has gained a pivotal position. By converting the power of the sun into electricity, solar energy is clean, green. It is a long term and non depletable resource with good employment potential, occupying a vivid position in the recent years. The energy demand projections for different sectors presents a varied picture , the energy intensity of GDP for Agriculture is projected to grow with more intensive cultivation.



## INTRODUCTION

Solar radiation sustains all forms of life on earth. According to estimates, sun radiates about  $1.74 \times 10^{17}$  W of power to earth. The main features of solar radiation are its wide spread distribution, inexhaustible supply and pollution free source of energy. Solar energy is not available at night, making energy storage an important issue in order to provide the continuous availability of energy. Both wind power and solar power are intermittent energy sources, viz., that all available output must be taken when it is available and either stored for when it can be used, or transported, over transmission lines, to where it can be used.

Solar energy is the cleanest and most abundant renewable energy source available. Modern technology can harness this energy for a variety of uses, including generating electricity, providing light or a comfortable interior environment, and heating water for domestic, commercial, or industrial use. Solar energy is a flexible energy technology: solar power plants can be built as distributed generation or as a central-station, utility-scale solar power plant. Some utility-scale solar plants can store the energy they produce for

use after the sun sets. The power from the sun intercepted by the earth is approximately  $1.8 \times 10^{11}$  MW. This makes it one of the most promising unconventional energy sources. Solar energy is available in abundance in most part of our country throughout the year. In India, the annual average daily solar radiation received over the whole of the country is around  $1800 \text{ J/cm}^2/\text{day}$ .

The sun's radiation provides for both heat and light energy from it. The energy harvested from the sun's radiation for various purposes on the Earth's surface is termed as solar energy which is of two types, solar thermal energy and solar photovoltaic PV energy. Solar energy, radiant light and heat from the sun, is harnessed using a range of ever-evolving technologies such as solar heating, solar photovoltaics, solar thermal electricity, solar architecture and artificial photosynthesis.

Most of energy on the earth is received from the sun. Solar energy creates circulation of wind and ocean water, causes water evaporation and consequent precipitation. Plants use solar energy for photosynthesis and store carbohydrates, protein, fats, oils,



alcohols, cellulose and lignin. In agricultural systems, energy is available from different sources as human, animal, sun, wind, biomass, coal, fertilizer, seed, agro-chemicals, petroleum products, electricity etc. Widespread use of solar energy for domestic, agricultural and agro-industrial activities has been practiced and increasing threat of acute shortage of the commercial sources of energy coupled with serious environmental pollution problems has accelerated interest in the scientific exploitation of renewable sources of energy.. Energy available from the sun is inexhaustible and environment friendly. Solar energy technologies are likely to play an important role in the near future through a variety of thermal applications and decentralized power generation and distribution systems.

Solar technologies are broadly categorized as either passive solar or active solar depending on the way they capture, convert and distribute solar energy. Active solar techniques include the use of photovoltaic panels and solar thermal collectors to harness the energy. Passive solar techniques include orienting a building to the Sun, selecting materials with favourable thermal mass or light dispersing properties, and designing spaces that naturally circulate air. Active solar technologies increase the supply of energy and are considered supply side technologies, while passive solar technologies reduce the need for alternate resources and are generally considered demand side technologies.

When considering solar PV in particular, there are two modes of utilization of power. In the off-grid mode, the solar PV panels generate electricity that is stored in battery banks and converted into AC from DC as required with the help of inverters and charge controllers. This is preferable for remote and/or rural areas. In the on-grid mode, the solar PV panels are connected to the grid with the help of appropriate inverters and charge controllers but without the need for a battery bank. It is to be noted that on-grid systems prerequisite the presence of grid infrastructure without which evacuation of the generated power is not feasible

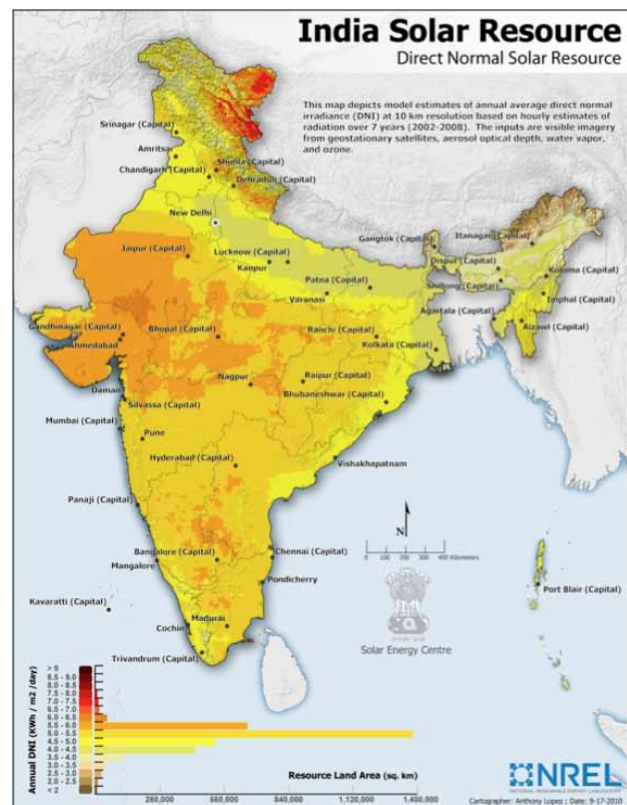

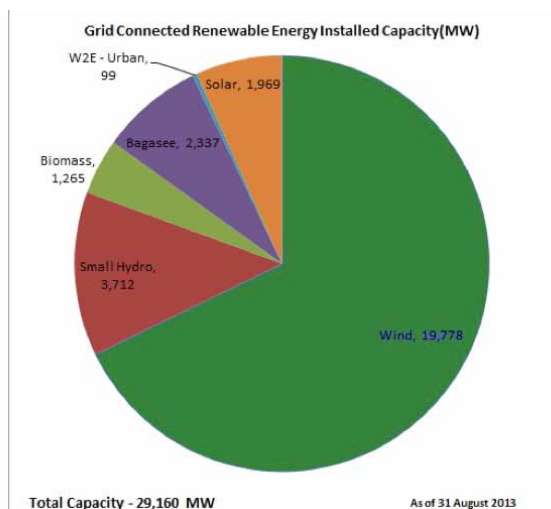

## Need for Solar Energy

With decreasing fossil fuel reserves across the world, increased pollution and global warming resulting in climate change, the need to shift a cleaner and greener source of energy to meet the demands of a growing population is of foremost importance. Increased use of thermal and nuclear energy pose their own set of risks. Hence, to effectively meet the power requirements, to enhance industrial growth and economic development, solar energy is a viable option when adopted on a large scale. India has a theoretical solar power reception of 600 TW. On an average, India receives 4-7 kWh/m<sup>2</sup> owing to the 300 plus clear sunshine days available. Despite the fact that commercial solar panel efficiencies are about 10%-15%, it still would be able to meet the demand for the nation if tapped appropriately. In the solar energy sector, some large projects have been proposed already, and 35,000 km<sup>2</sup> area of the Thar Desert has been set aside for solar power projects, sufficient to generate 700 GW to 2,100 GW.

## Total Installed Photovoltaic Peak Power Capacity (MWp) by 2012

| Country        | Capacity |
|----------------|----------|
| European Union | 68,640   |
| Germany        | 32,509   |
| Italy          | 16,987   |
| China          | 8,043    |
| USA            | 7,665    |
| Japan          | 6,704    |
| France         | 3,843    |
| Australia      | 2,291    |
| India          | 1,839    |
| UK             | 1,831    |

## Government Support

The State and Central Government have announced various schemes and policies to promote the installation and propagation of solar energy among both HT and LT consumers. The National level solar subsidy amounts upto 30% of the total capital cost of the installed solar system which the consumer can avail. Apart from this, several other schemes, such as the one provided by the NABARD allows easier access to solar by rural communities.

Jawaharlal Nehru National Solar Mission (JNNSM) is an important program of the Government of India under Renewable Energy sector aims at establishing India as a global leader in solar energy by creating policy conditions for its diffusion across the country. It is the major initiative to promote ecologically sustainable growth while addressing India's energy security challenge. Phase I of the Mission has a target to achieve 1000 MW of installed capacity, of which the State target is 22MW.



## Jawaharlal Nehru National Solar Mission

| Application Segment                | Target for Phase I (2010-13) | Cumulative Target Phase II (2013-17) | Cumulative Target Phase III (2017-22) |
|------------------------------------|------------------------------|--------------------------------------|---------------------------------------|
| Grid Solar Power including rooftop | 1,100                        | 4,000                                | 20,000                                |
| Off-grid solar applications        | 200                          | 1,000                                | 2,000                                 |

Source: Ministry of New and Renewable Energy

## Tamil Nadu Solar Energy Policy 2012

Tamil Nadu has a very good solar potential with 300 clear sunny days as it receives very high solar radiation. The Government of Tamil Nadu is committed to promote renewable energy generation in the State and has come out with **“Tamil Nadu Solar Energy Policy – 2012”** which aims at generating 3000 MW of solar power by 2015 with a vision of developing the State as a world leader in Solar Energy. “Tamil Nadu Solar Energy Policy 2012” aims to :

- To achieve energy security
- To reduce carbon emissions
- To project Tamil Nadu as a Solar Hub
- To generate 3000 MW of Solar Energy by 2015
- To achieve grid parity by 2015
- To encourage indigenous solar manufacturing facilities in the State
- To promote Research and Development in the solar energy sector and hybrid systems
- To create skilled man power and employment in a new industry

## Tamil Nadu State Solar Policy 2012

| Phase (2013-2015) | Utility Scale (MW) | Rooftop PV (MW) | REC(MW) | Target (MW) |
|-------------------|--------------------|-----------------|---------|-------------|
| 2013              | 750                | 100             | 150     | 1000        |
| 2014              | 550                | 125             | 325     | 1000        |
| 2015              | 200                | 125             | 675     | 1000        |
| Total (by 2015)   | 1500               | 350             | 1150    | 3000        |

Apart from encouraging indigenous solar manufacturing facilities with incentives, the policy aims at promoting research and development in the sector and hybrid systems, besides creating skilled manpower and jobs. Tamil Nadu Energy Development Authority (TEDA) is the nodal agency for guaranteed single window clearances to be made within 30 days so that the plants to be commissioned in less than 12 months.

The State promotes the solar energy through promotion of Solar Rooftop Systems (Domestic) – Generation Based Incentive of 2 per unit for first two years, 1 per unit for next two years and 0.5 per unit for subsequent years. Solar Parks is being set up with a capacity of about 50 MW each in 24 districts - Establishment of exclusive Solar Manufacturing Parks to promote solar manufacturing industries in these parks is being setup. Promotion of Rooftops in Government buildings and all street lights and water supply installations in local bodies has been taken up and Installation of Solar Water Heating System for buildings, new houses/hotels and industries is made mandatory.

## Solar in Agriculture

Tamil Nadu is richly endowed with fertile lands and agro climatic zones suitable for a varied agricultural produce. "Vision Tamil Nadu 2023" envisages an investment of Rs. 55000 crore in the solar power projects in Tamil Nadu. Although many farms would find it difficult to become completely solar powered, natural methods of harnessing solar energy and installing solar panels has been a viable alternative. Drying of various agricultural produce in open sunlight is an age-old practice. Development of various solar devices for thermal applications such as water heating and space heating, drying, cooking and power generation has been the order of the day. Solar cookers, Solar dryers, Solar water heater, photo voltaic systems are commonly used. In solar photo voltaic (SPV) technology the solar radiation falling on a device called solar cells are converted directly into electricity without any environmental pollution. Solar pumping systems are ideal for lifting water for drinking and irrigation without harming the

environment. These pumps can be installed in boreholes, tanks, cisterns or rivers etc.

The solar pumps use the solar photovoltaic energy to pump water for agricultural and other purposes. A wide variety of pumps ranging from DC surface to submersible AC pumps are available. They also require a pump controller to adjust for the variation of solar radiation through the day. DC surface pumps are designed for high flow rates and low heads. The DC motor driving the surface pump is powered by matching solar arrays to maximize efficiency. AC submersible pumping systems are designed for high head and medium flow applications. Solar PV water pumping systems are used for irrigation and drinking water. The majority of the pumps are fitted with a 200–3,000 watt motor that are powered with 1,800 Wp PV array which can deliver about 140,000 litres of water per day from a total head of 10 metres.





Solar energy is a constant energy and does not rely on the burning of harmful fuels to generate electricity. Solar power is non-polluting and it does not contribute to global warming or greenhouse gas emissions. Solar power allows those in remote locations to live off the grid without having to rely solely on noisy generators. It is part of the solution, to becoming energy self-sufficient. Solar energy is renowned for its versatility – it can be used to power anything from a tiny torch to a satellite in space. However solar energy relies upon enough sunlight reaching the photovoltaic cells – on cloudy days there may not be enough sunshine to produce sufficient electricity and production shuts down completely at night so back-up energy sources are necessary. Solar Energy helps the farmers control energy costs when pumping water or during drought and is profitable alternative to low margin crops. Solar energy for processing plants helps to provide reliable electricity to meet demand at peak processing times and hedge against volatile electricity prices. Solar energy for cold storage helps to offset high electricity loads by producing on-site solar electric power.

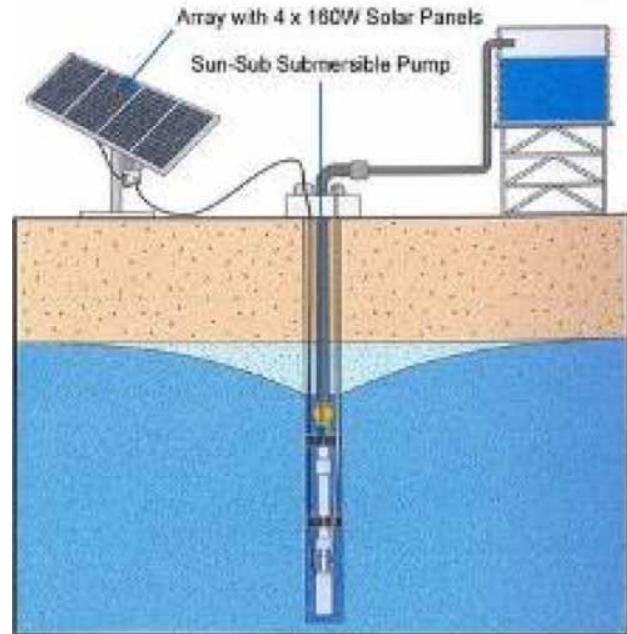



Agricultural farming, processing and storage have high and variable energy needs. As a result, unexpected changes in electricity prices can have a costly impact on finance. Providing a consistent energy source at lower fixed rates, has attained utmost importance for ensuring that business has affordable solar electric power. It has become easier and more affordable to use solar power on a farm due to the rapid advancements in technology and the increasing awareness about renewable energy sources.

In this session , Mr. Ravi Karamcheti, MD, Solar Water Pumps- Sun Edison India, highlighted on the use of the solar powered pumps for farming activity in the state. agriculture contribute around 13% to state GDP with 40% of population involved in Agricultural activities with the cropping intensity of around 1.18. The contribution of food grains is around 3%, vegetables 7%, fruits 12%, and flowers 24% to National produce.

Gross Cropped Area in TN (lakh sq. km)

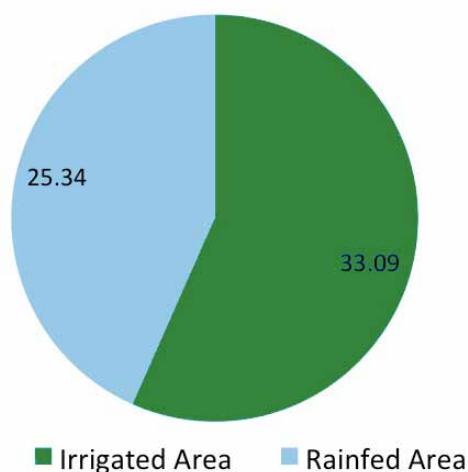

Agriculture being a primary sector plays a vital role in the economic growth of the state. Factors like erratic and inadequate monsoon rain , low cropping intensity depletion of ground water ,deterioration of soil health and yield gaps in majority of the crops have resulted in the reduction of crop yields. Agricultural yield and productivity is interlinked with varied factors , the crux being the technological advancement and the use of modern techniques which interlinks with the power availability to operate the pumpsets, motors etc.

The power situation in the state depicts that the installed capacity of conventional energy sources is 10,515.34 MW while the non-conventional is 8,060 MW. The energy demand is 10,000 MW to 12,300 MW and the average energy availability is 8,500 MW. Considering the growing demand for the electricity , solar energy becomes highly dependable. Solar Water Pumps will directly impact on :

- **Agriculture** through Improving the yield of per unit of land/ water and accelerating innovation and extension mechanism and ensure timely irrigation
- **Water** through Improvement in irrigation practices and reduction of water losses, promoting of efficient use of water by modernization of irrigation systems, improved service delivery, participation of farmers and popularization of micro irrigation Crop Group Historical Yield Trend

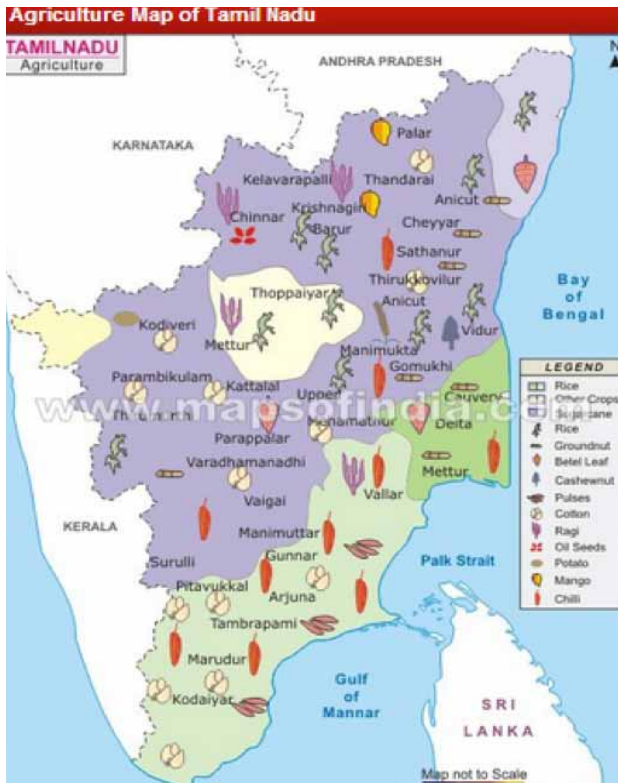

### Yield gap in major crops

| Crop          | Potential Yield (Kg/ha) | Average Yield (Kg/ha) | Yield Gap (Kg/ha) |
|---------------|-------------------------|-----------------------|-------------------|
| Paddy (I)     | 6000                    | 5275                  | (-) 725           |
| Cholam (I)    | 6000                    | 3008                  | (-) 2992          |
| Ragi (I)      | 4750                    | 2527                  | (-) 2223          |
| Red gram      | 1500                    | 667                   | (-) 833           |
| Black gram    | 1270                    | 389                   | (-) 881           |
| Groundnut (I) | 2850                    | 2481                  | (-) 369           |
| Sugarcane (I) | 146000                  | 109000                | (-) 37000         |
| Cotton (I)    | 730                     | 426                   | (-) 304           |

Source : Dept. of Economics, TNAU.2006 : Coimbatore-641003 stands for Irrigated

As per Central Electricity Authority's 2012 General review, there a total number of 20.9 lakh agricultural electric pump has been energized and around 20% (~2000 MW) power is consumed annually in agriculture sector. The current power scenario shows that 21% of the power is utilized by Agriculture sector. The irrigation profile emphasis that 56% of the lands are irrigated by pumpsets while 18% of the lands are irrigated through tanks and 26% through canals.

Free supply of power to agriculture plays a major role in the agricultural development though certain factors like power cuts, act as a impediment to the development. This session further highlighted on the solar water pump system and its component description.

- High efficiency PV modules generate power
- DCPM optimizes power output at module level
- Controller performs system level MPPT and drives pump at variable speed to match input power to required power
- High efficiency 3-phase AC pump delivers water from source

Solar water pumps creates a difference for irrigation farmers by enhancing the customer value proposition through Intermittent grid power which enables to do day time irrigation, opportunity to utilize full land holding and option to grow high profit crop such as cash crop. For the diesel pump users, solar pumps enables diesel abatement, opportunity to utilize full land holding and to increase crop intensity.





Case studies on the use of the solar pump in Agriculture and its success were also presented in this session.

### **Solar pump: Case study**

#### **Solar pump : Case Studies (1)**

##### **Farmer Situation:**

- Mr. OVR Somasundaram is a renowned agriculturist from Tamil Nadu
- Pioneered the concepts of intercropping of Nutmeg and Cocoa to maximize yield
- One of the most prosperous farmers in Coimbatore

##### **Problem:**

- Intercropping tremendously increases water requirement
- Two open wells supply sufficient water
- Infrequent electricity however, only at night time
- Night time labour expensive to hire
- Unwilling to use the polluting diesel alternative

##### **Solution:**

- SunEdison designed, supplied, installed and commissioned a 10HP water pump in his one of the existing open well
- Did not require any financial assistance, in recognition of the value added
- First TN farmer to install a 10 HP solar pump in TN

##### **Value Add :**

- 20 acres of land covered through drip irrigation
- Water delivered 1.2 km away from source
- Reduced night time labour requirement
- Mr. Somasundaram plans to equip all existing electric pumps with solar technology.



##### **OVR Somasundaram, Pollachi**

- Depth of water : 30 meters
- Cultivation: 25 Acres (Coconut)
- Type of Irrigation: Drip
- System Size : 10 HP (8.4kW)



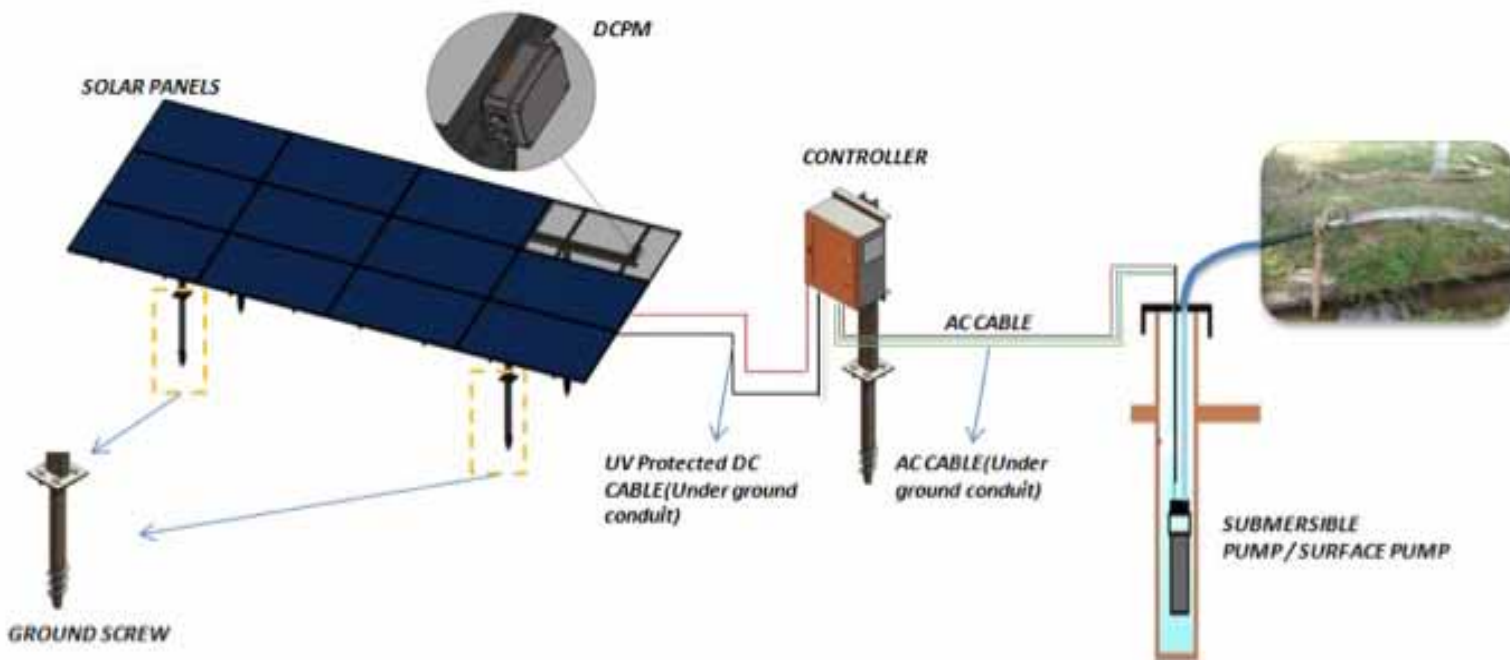

## Solar pump : Case Studies (2)

### Farmer Situation:

- Mr. Srirangan owns five acres of land in Anaimalai village in Coimbatore district
- After retirement from a government job, he chose agriculture to meet his ends.
- 1/4th land used for coconut plantation.

### Problem:

- Intermittent, low quality power supply
- 3/4th land free for cattle rearing: restricted by lack of good water supply
- Bore well constructed: diesel pump ineffective for such low depths

### Solution:

- Heard about SunEdison solar pumps in 2011
- Arranged for loan from nationalized bank
- SunEdison designed, supplied, installed and commissioned a 5HP solar pump
- Compatible with drip irrigation to optimize water use

### Value Add :

- Banana cultivation started on free land
- Tank created to store excess water for cattle rearing
- Mr. Srirangan now earns more than what he used to in his Government Job.



### Srirangan, Coimbatore

- Depth of water : 150 meters
- Cultivation: 5 Acres
- Type of Irrigation: Flood
- System Size : 5 HP (4.2kW)

In this session Mr. Rangarajan Ramaswamy, Director, Service and Training, Grundfos Pumps India Pvt Ltd, presented on the benefits of solar water pumps in agriculture. Solar pumping solution for agricultural market has dual approaches viz., Supply Side Management and Demand Side Management. Solar pumping solutions could be the right option to support desired /adequate water requirement for agriculture needs. Inefficient pumps used results in consuming high energy. Power savings through solar pumps has been the wider option and on the demand side, Solar water pumps helps the farmers through lower Pump Failure rate and less maintenance and higher agricultural yield.

This session highlighted on the earlier techniques used in the solar water pumps and the improvements to the latest techniques.

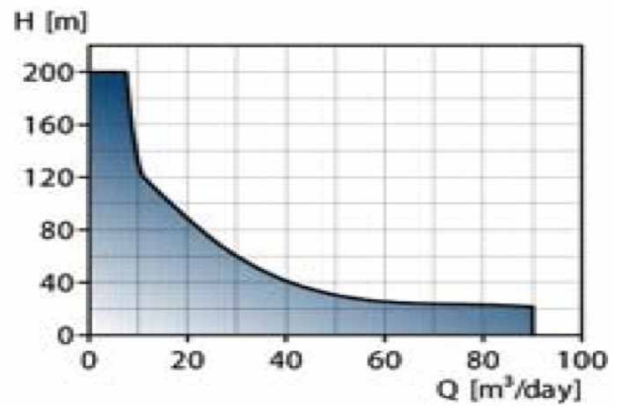

**Renewable History**

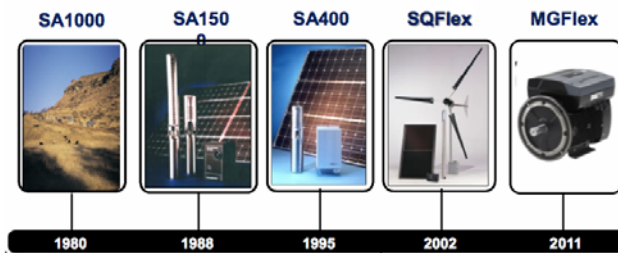

**PRODUCT FEATURES**

- Centrifugal or Helical version
- Compatible to Solar, Wind or Combi System
- Simple installation
- Reliable water supply
- Virtually no maintenance
- Expansion possibilities
- Cost-efficient pumping
- Dry-running protection

**PERFORMANCE RANGE**

|                    |                                       |
|--------------------|---------------------------------------|
| Flow Q (Max)       | 90 m³/day                             |
| Head H (Max)       | 200 m                                 |
| Liquid Temp. (°C)  | 0 °C to 40 °C                         |
| Voltage Supply     | 30 – 300 VDC<br>Or 1x90-240V, 50/60Hz |
| Installation Depth | Max 150 m                             |

## Grundfos Solar Submersible Pump- SQ Flex



### Helical Rotor SQFlex

High Head Performance  
 3" diameter pump end  
 5 different variants

### Centrifugal Rotor SQFlex

High Flow Performance  
 4" diameter pump end  
 6 different variants

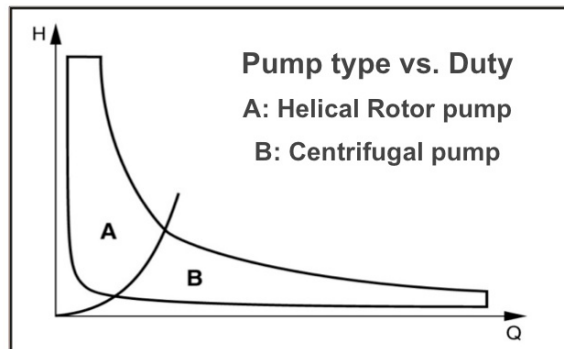

## Grundfos Solar Surface Pump - CRFlex



MGflex Motor

CR Pump

MGflex is an high efficiency motor

Wide Voltage Range

Known-good reliability history

One-stop product solution

MPPT software

AC/DC compatibility

Connection to solar, generator or grid

Motor protection

Sensor and switches connection

High efficiency hydraulic

Known-good reliability track record

Wide range of material combinations

Easy installation

Various connection solutions



## Grundfos Solar Surface Pump - CRFlex



| PERFORMANCE RANGE    |   |
|----------------------|---|
| Flow ( Q ) , Max     | 32 cum/hr                                     |
| Head (H) Max         | 150m  |
| Liquid temp, Deg C   | 0 to 120 Deg C                                |
| Power input P1 (Max) | 1730W   |
| Current (Max)        | 8.9A  |
| Speed (Max)          | 3600 RPM                                      |
| Voltage Supply       | VDC 30 – 300V DC<br>VAC 1x90-240V,<br>50/60Hz |

### SP / CR + inverter – higher capacities

#### Submersible pump with external inverter

- Flow range : 1.5cum/hr to 180 cum/hr
- Head range : upto 500m
- Motor capacity : 2.2 to 18.5 KW
- Voltage : 3X220V AC ( 2.2 to 4KW) and 3X415 V AC (5.5 to 18.5KW)
- 150-450 V DC ( 2.2 to 4KW) and 450-800VDC (5.5 to 18.5KW)

#### CR ( Inline pumps ) with external inverter

- Flow range : 2cum/hr upto 100 cum/hr
- Head range : 20 to 220m
- Temperature : upto 120 Deg C
- Motor capacity : 2.2 to 18.5KW , 3X415V AC, 450-800VDC

Certain installations carried out through the solar pumps were highlighted in this session.

**Typical Village installation in Maharashtra for drinking water – Pump SQF 2.5-2 below the hand pump**

**7500 LPD @ 90m, input power -900W**



**Nellore SQF 8A-5-48000 to 50000 LPD at 80 Feet**





## Installations

Badami, Karnataka

Application : Irrigation

SQF 3A-10

Flow : 35000 LPD @55m



Karur, Tamil Nadu

Application : Irrigation

SP 3A with 4 KW motor

Flow : 3.5 m<sup>3</sup>/hr @ 170 m





**Sivaganga, TN (Irrigation 180,000 LPD @ 30 M, 4 KW)**



**Bangladesh : Irrigation Project. SP60-3, 5.5KW, 300,000 LPD @ 20m**



In this session, presentation by Mr. Ravikumar Kandasamy, of Mahatma Gandhi Institute of Rural Industrialisation (MGIRI), Mumbai highlighted on the energy conservation and the Green Practices for Agriculture through use of the solar power. The Session stressed on the innovative green initiatives available in the Agro-Industries through renewable energy mainly through solar energy. Agro-Industries may differ from the Large Industries either in scale or in different aspects but energy, is the prime necessity which is not fully available in rural sector and for SME's. Rural industries (specifically Micro & Small industries) have the advantage of being small and also get the energy needs through renewable energies or energy conservation through locally available resources, redesign of the existing systems, in man - machine combination through innovations.

Solar Applications in Cotton to Garment Processing is highly effective since it is possible to promote the decentralized solar applications through segmenting the textile process machineries and coupling suitable DC drive systems instead of AC thereby optimizing the power requirements of the process machineries for renewable energy applications to justify internal rate of returns (IRR) and to utilize the locally available renewable energy resources thereby providing sustainable employment round the year. The use of solar energy in various applications commonly used were also presented in this session. The use of solar energy in the garment business and its machinery is highlighted below:

### Solar Cotton to Garment Business Unit



### Mini Solar Spinning Unit



### Solar Powered Power-looms in Tirupur & Auroville, T.N





## Agriculture & Processing Machineries

### Solar Pumping



The use of Solar powered machines used for Agricultural processing and artisans are shown below:



### Poulties & Hatcheries



150 Yellow CFL (16 W)

### Solar Fodder Machine



### Solar Fruit Grader



Replaced with Yellow LED's (4 W)





## Artisan Guilds

### Solar Micro Tools



### Solar Potter wheel

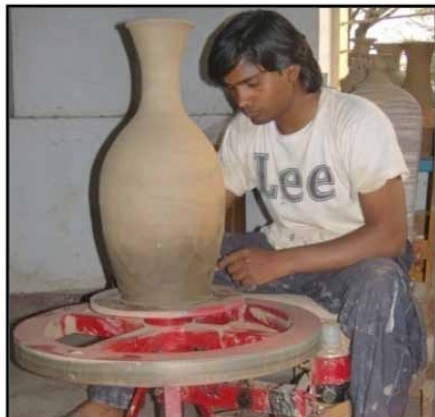

### Energy efficient potter kiln



## Other Micro & Small Enterprise Applications identified & conditioned for Green Energy

### Dhoop-batti machine



### Solar Handicapped Tricycle



Liquid Filler



## Food Industries

Solar Micro Dal Mill



Solar Food Drier



Auger Filler



Vegetable Cutting Machine



Food industries play a key role for development and use of the solar energy in varied activities in the food industries is shown below:



## Solar Powered Sheds & Buildings



LED Indoor & Outdoor lightings

The presentations highlighted on the concept of utilizing Renewable Energy in the villages for varied applications. Renewable energy concept in villages focusing on the micro level applications through solar power were presented which would serve for energy efficiency and saving power and facing the challenges ahead in the energy sector.



Innovative Solar Cooler





A hut demonstrating solar powered textile unit



A hut demonstrating solar indoor & outdoor LED lighting, solar fan, solar cooler, laptop/mobile charger etc.



A hut Demonstrating solar micro tool & solar potter wheel for artisan gild

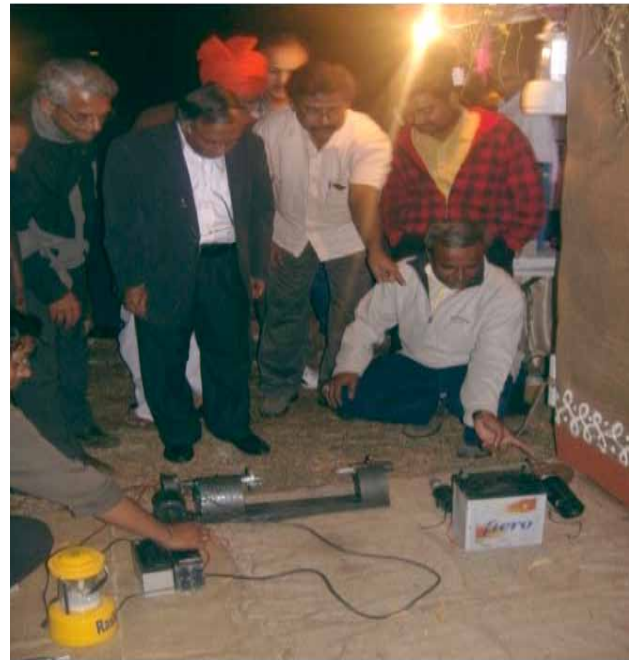



A hut demonstrating biomass based products and charcoal briquettes



Biogas based power back-up system & Panchagavya products like Dhoop-batti machine, mosquito repellent coil machine, cow urine based phenol etc.



A hut with other rural industry set-ups like solar dal mill, liquid filling machine, auger filling machine & packaging machine



Solar PV potential of each district

### Independent PV Potential -TAMIL NADU

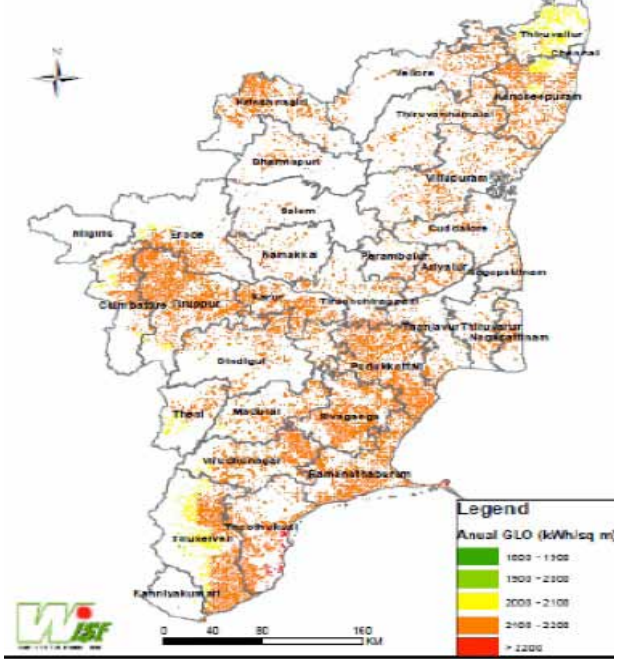

### Independent CSP Potential -TN

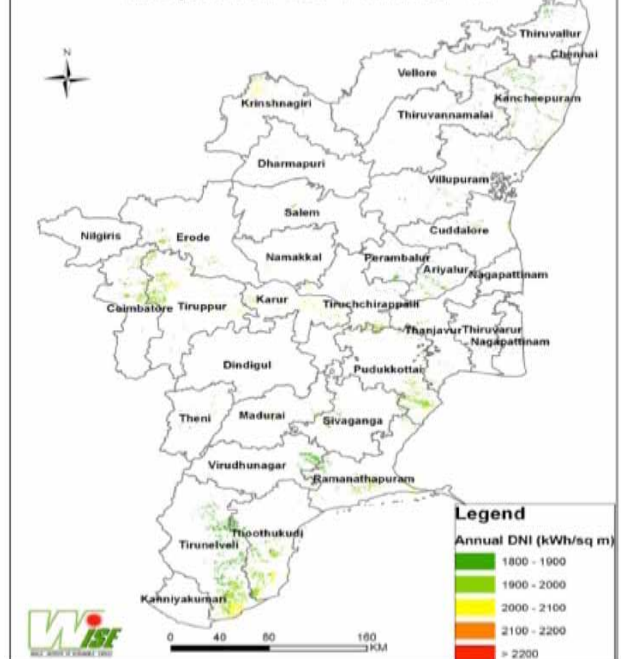

| No.          | District Name     | Avg Ann GHI<br>Kwh/sq m | Area<br>Sq km | Potential<br>MW |
|--------------|-------------------|-------------------------|---------------|-----------------|
| 1            | Ariyalur          | 5.82                    | 73            | 3650            |
| 2            | Chennai           | 5.77                    | 1             | 70              |
| 3            | Coimbatore        | 5.84                    | 172           | 8576            |
| 4            | Cuddalore         | 5.83                    | 61            | 3047            |
| 5            | Dharmapuri        | 5.88                    | 23            | 1136            |
| 6            | Dindigul          | 5.89                    | 73            | 3647            |
| 7            | Erode             | 5.93                    | 127           | 6354            |
| 8            | Kancheepuram      | 5.78                    | 293           | 14648           |
| 9            | Kanniyakumari     | 5.86                    | 1             | 55              |
| 10           | Karur             | 5.97                    | 149           | 7440            |
| 11           | Krinshnagiri      | 5.90                    | 139           | 6928            |
| 12           | Madurai           | 5.88                    | 106           | 5319            |
| 13           | Nagapattinam      | 5.84                    | 37            | 1828            |
| 14           | Namakkal          | 5.96                    | 16            | 795             |
| 15           | Nilgiris          | 5.26                    | 0             | 16              |
| 16           | Perambalur        | 5.78                    | 34            | 1711            |
| 17           | Pudukkottai       | 5.86                    | 465           | 23226           |
| 18           | Ramanathapuram    | 5.88                    | 364           | 18177           |
| 19           | Salem             | 5.92                    | 18            | 897             |
| 20           | Sivaganga         | 5.84                    | 427           | 21359           |
| 21           | Thanjavur         | 5.84                    | 55            | 2752            |
| 22           | Theni             | 5.79                    | 61            | 3051            |
| 23           | Thiruvallur       | 5.73                    | 111           | 5556            |
| 24           | Thiruvannamalai   | 5.79                    | 95            | 4732            |
| 25           | Thiruvarur        | 5.81                    | 23            | 1167            |
| 26           | Thoothukudi       | 5.87                    | 384           | 19205           |
| 27           | Tiruchchirappalli | 5.88                    | 122           | 6100            |
| 28           | Tirunelveli       | 5.77                    | 746           | 37310           |
| 29           | Tiruppur          | 5.95                    | 491           | 24554           |
| 30           | Vellore           | 5.80                    | 105           | 5255            |
| 31           | Villupuram        | 5.81                    | 111           | 5571            |
| 32           | Virudhunagar      | 5.80                    | 311           | 15554           |
| <b>TOTAL</b> |                   |                         | <b>5194</b>   | <b>259685</b>   |

| Sr           | District Name     | Avg Ann DNI<br>kWh/sq m | Area<br>Sq Km | Potential<br>MW |
|--------------|-------------------|-------------------------|---------------|-----------------|
| 1            | Ariyalur          | 5.18                    | 49            | 1716            |
| 2            | Chennai           | 5.06                    | 1             | 41              |
| 3            | Coimbatore        | 5.41                    | 105           | 3668            |
| 4            | Cuddalore         | 5.22                    | 35            | 1211            |
| 5            | Dharmapuri        | 5.40                    | 5             | 173             |
| 6            | Dindigul          | 5.39                    | 6             | 224             |
| 7            | Erode             | 5.42                    | 53            | 1865            |
| 8            | Kancheepuram      | 5.13                    | 159           | 5555            |
| 9            | Kanniyakumari     | 5.01                    | 0             | 0               |
| 10           | Karur             | 5.49                    | 50            | 1752            |
| 11           | Krinshnagiri      | 5.48                    | 48            | 1670            |
| 12           | Madurai           | 5.31                    | 25            | 858             |
| 13           | Nagapattinam      | 5.23                    | 15            | 512             |
| 14           | Namakkal          | 5.46                    | 4             | 135             |
| 15           | Perambalur        | 5.13                    | 21            | 725             |
| 16           | Pudukkottai       | 5.30                    | 172           | 6036            |
| 17           | Ramanathapuram    | 5.40                    | 124           | 4347            |
| 18           | Salem             | 5.23                    | 8             | 293             |
| 19           | Sivaganga         | 5.24                    | 53            | 1841            |
| 20           | Thanjavur         | 5.23                    | 31            | 1080            |
| 21           | Theni             | 5.29                    | 21            | 719             |
| 22           | Thiruvallur       | 5.03                    | 29            | 1022            |
| 23           | Thiruvannamalai   | 5.09                    | 35            | 1211            |
| 24           | Thiruvarur        | 5.15                    | 10            | 366             |
| 25           | Thoothukudi       | 5.38                    | 248           | 8664            |
| 26           | Tiruchchirappalli | 5.33                    | 63            | 2208            |
| 27           | Tirunelveli       | 5.28                    | 511           | 17872           |
| 28           | Tiruppur          | 5.44                    | 202           | 7086            |
| 29           | Vellore           | 5.14                    | 39            | 1364            |
| 30           | Villupuram        | 5.16                    | 52            | 1829            |
| 31           | Virudhunagar      | 5.04                    | 71            | 2483            |
| <b>TOTAL</b> |                   |                         | <b>2244</b>   | <b>78525</b>    |

District-wise CSP potential



Solar energy is highly essential renewable energy sources that has immense potential in Agriculture and the post harvest management. The use of solar power as a source of energy in varied agricultural activities was presented by Dr. S. Kamaraj, Professor and Head, Dept of Bio energy, Tamil Nadu Agricultural University, Coimbatore. The Grid interactive power capacity at the National level has stood at 28708.95 MW as on 30.6.13 as shown below:

| GRID-INTERACTIVE POWER (CAPACITIES IN MW) |           |
|---|-----------|
| Wind Power                                | 19,564.95 |
| Small Hydro Power                         | 3,686.25  |
| Biomass Power & Gasification              | 1,264.80  |
| Bagasse Cogeneration                      | 2,337.42  |
| Waste to Power                            | 96.08     |
| Solar Power                               | 1,759.44  |
| Total                                     | 28,708.95 |

Harnessing the solar energy through various modules were highlighted in the presentation.

**Harnessing the solar energy**

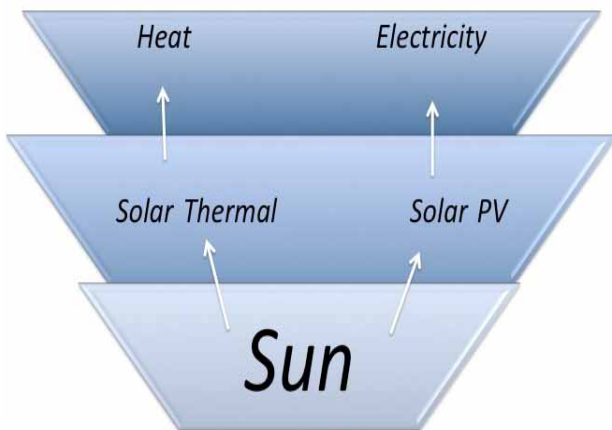

**Solar modules**

- Available solar module size 5 watt to 300 watt
- One silicon cell- 0.5 volts
- So 30- 35 cells combined together to charge 15 V battery

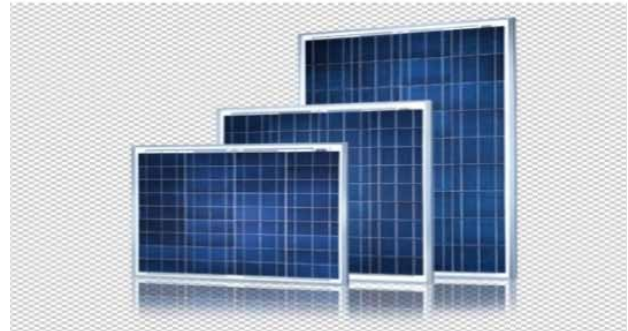

| Cell type                      | Efficiency of cell                             | Land per MW   |
|--------------------------------|--|---------------|
| Mono crystalline silicon       | Around 18 – 24 %                               | 3 – 4 acres   |
| Poly/Multi crystalline silicon | Around 14 – 18 %                               | 4 – 5 acres   |
| Thin film (different types)    | Amorphous silicon<br>6 – 10 %                  | 7.5 – 9 acres |
|                                | Cadmium Telluride<br>10 – 11 %                 |               |
|                                | Copper Indium Gallium Di selenide<br>12 – 14 % |               |

## Solar PV home lighting system



|         |                    |
|---------|--------------------|
| Model 1 | * 1 light          |
| Model 2 | * 2 lights         |
| Model 3 | * 1 light & 1 fan  |
| Model 4 | * 2 lights & 1 fan |
| Model 5 | * 4 lights         |

### Setup - a solar PV module, battery, inverter, charge controller and DC & AC load.

Simple PV power systems run pumps directly when the sun is shining, so they work hardest in the hot summer months when they are needed most. Generally, batteries are not necessary because the water is stored in tanks or pumped to fields and used in the daytime. Larger pumping systems may include batteries, inverters, and tracking mounts to follow the sun. Some of this solar application models, its components & specification are detailed below :

### Solar Pump

#### Available models

- DC surface pump (high flow rates and low heads)
- AC submersible pump (medium flow rates and high heads)

Tentative cost – 1 lakh/ 1 kW capacity

MNRE subsidy – Rs. 81/ watt

( maximum upto Rs. 50,000/ system )

|                              | AC            | DC              |
|------------------------------|---------------|-----------------|
| SPV rating (W)               | 75 x 16/24    | 75 x 12/24      |
| Dimensions, Panel LxWxH (mm) | 960x430x 40   | 960x430x 40     |
| Pump rating (kW)             | 1.0-1.5       | 0.75-1.5        |
| Total head (m)               | 50            | 10              |
| Discharge (l/day)            | 17,625-35,000 | 70,000-1,35,000 |



### Solar Water Pumping

| Solar Panels       | Capacity 3 HP                                     | 5 HP                                      | 7.5 HP                                    | 10 HP                                     |
|--------------------|---|---|---|---|
|                    | 3000 W  | 5000 W                                    | 7500 W                                    | 10000 W                                   |
| Bore well Pumps    | • 60,000 litres/day<br>• From 30 m Deep           | • 1,00,000 litres/day<br>• From 30 m Deep | • 1,50,000 litres/day<br>• From 30 m Deep | • 2,00,000 litres/day<br>• From 30 m Deep |
| Controlling System | Switch & Controllers                              | Switch & Controllers                      | Switch & Controllers                      | Switch & Controllers                      |
| Approximate Cost   | Rs. 3 Lakhs                                       | Rs. 5 Lakhs                               | Rs. 7.5 Lakhs                             | Rs. 10 Lakhs                              |
| Accessory parts    | Cable & Iron rods for supporting the Solar panels |   |   |   |

## Solar Street Light



### Components

- Two photovoltaic modules of 36 Watts
- A six-meter lamppost for charging.
- A storage battery and an inverter unit.
- Tentative cost – Rs.25,000/- to Rs.35,000/
- MNRE subsidy – 30% of cost subject to Rs. 81/ watt

|                            |                            |
|----------------------------|----------------------------|
| SPV rating (W)             | 8                          |
| Dimensions of module (mm)  | (960-980) × (430-450) × 40 |
| Dimensions of Lantern (mm) | 393 × 310 × 100            |
| CFL rating (W)             | 2 x 20                     |
| SMF battery                | 12V,40Ah                   |

## Solar lantern



### Components:

- SPV module of 10 Wp capacity,

- rechargeable battery,
- Compact Fluorescent lamp (CFL) of 5 / 7W and
- electronics (i.e. inverter and charge controller)

Cost – Rs. 3000 ( including solar module 10 Wp)

|  |             |
|--|-------------|
| SPV rating (W)                             | 8           |
| Dimensions, Panel Length×Width×Height (mm) | 560×260× 60 |
| Dimensions, Lantern Diameter× Height (mm)  | 240×450     |
| CFL rating (W)                             | 7 and 9     |
| SMF battery                                | 12. 7 Ah    |

## Solar fencing

Solar fencing helps to protect the crops from forest animals . Solar fencing includes the solar panel, energiser ,battery ,fencing systems .



Solar thermal applications and its nature of performance were highlighted in this session ushering the importance of harnessing the solar energy. Solar cooker, Solar water heaters, Solar tunnel dryer, Solar distillation and Solar pond etc. are certain application modes of solar energy .



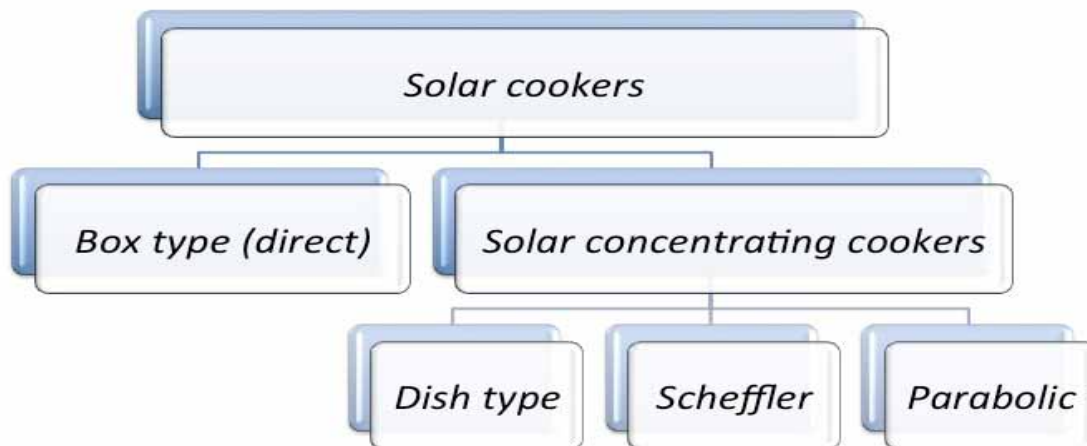
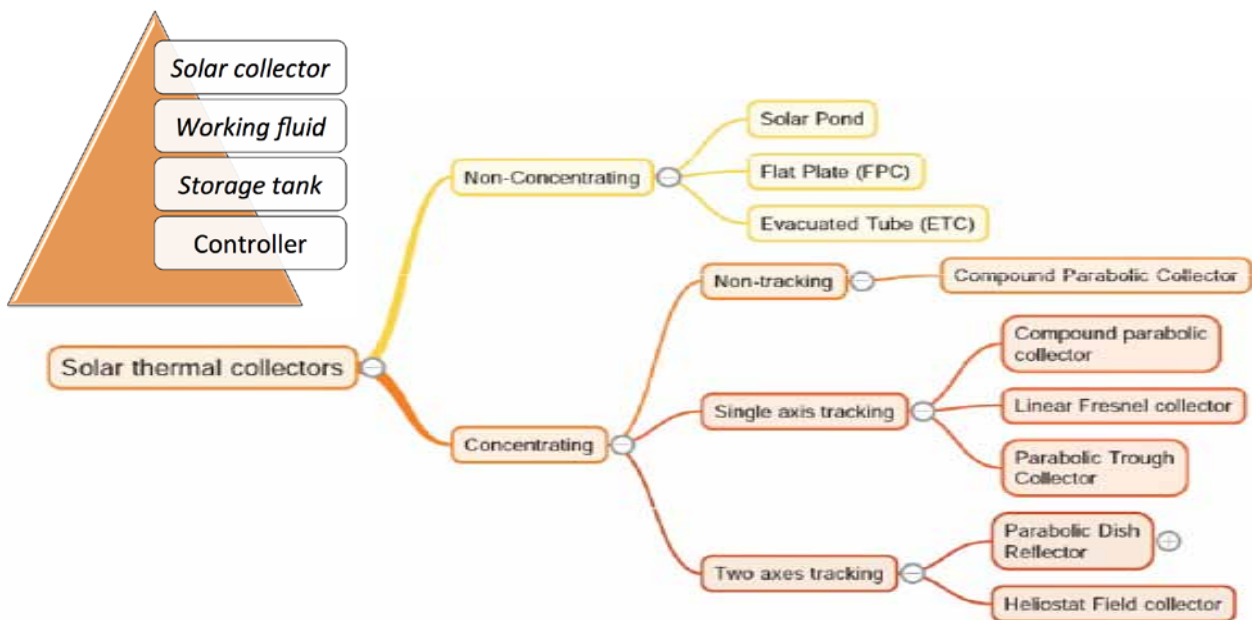
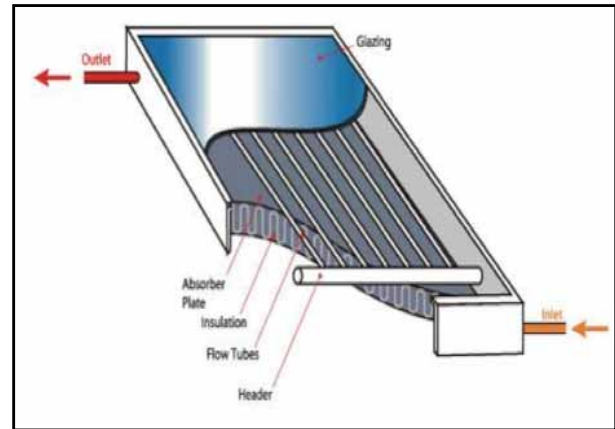
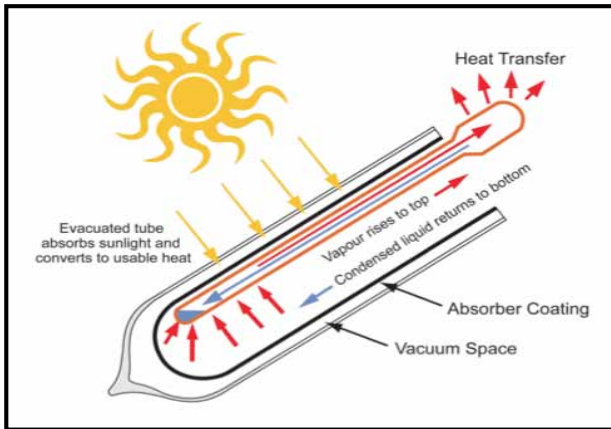

### Box type solar cookers

|                                    |                                 |
|------------------------------------|---------------------------------|
| <b>Overall Dimensions</b>          | 500 x 500 x 200                 |
| <b>Weight (kg)</b>                 | 12                              |
| <b>Time taken in cooking (min)</b> | rice, 45-60, vegetables 60-100. |
| <b>Conversion efficiency (%)</b>   | 35-40                           |

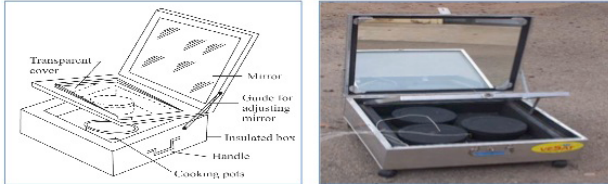

### Dish type solar cookers

|   |              |
|---|--------------|
| <b>Shape</b>                                | Parabolic    |
| <b>Tracking adjustment</b>                  | Manual       |
| <b>Aperture diameter &amp; focal length</b> | 1.4m & 0.28m |



### Scheffler cookers

|                             |  |
|-----------------------------|--|
| <b>Temperature</b>          | Attain upto 450°C                        |
| <b>Area</b>                 | 8 Sq. m                                  |
| <b>Life time (in years)</b> | Reflector - 5<br>Metallic structure - 15 |

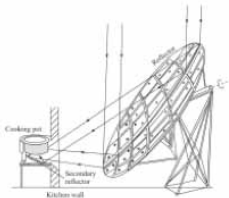

### Parabolic concentrating cooker



Cost :80 lakhs (1000 people )

Subsidy from MNRE: maximum upto 30%

Fuel savings : 20 lakhs/ annum

### Solar water heaters

#### 1. Flat plate solar water heater

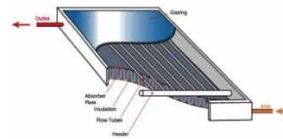

#### 2. Evacuated tube solar water heater

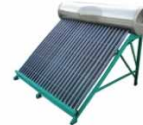

Commercial dairy farms use large amounts of energy to heat water that is used to clean equipment. Heating water account for upto 40% of the energy used on a dairy farm. Solar water heating systems may be used to supply all or part of these hot water requirements.

### Solar still

|                         |  |
|-------------------------|--|
| <b>Use</b>              | To produce distilled water   |
| <b>Capacity</b>         | 3 liters / day.  |
| <b>Salient Features</b> | No fuel, utilize solar thermal energy.<br>Pollution free.<br>Simple and easy to install. |



Designed By Dept of Bio Energy, Tamil Nadu Agricultural University, Coimbatore



## Crop Drying Operations

The simplest and least expensive technique is to allow crops to dry naturally in the field, or to spread grain and fruit out in the sun after harvesting. The disadvantage of these methods is that the crops and grain are subject to damage by birds, rodents, wind, and rain, and contamination by windblown dust and dirt. More sophisticated solar dryers can protect grain and fruit, reduce losses, dry faster and more uniformly, and produce a better quality product than open-air methods .

### Solar tunnel dryer

|                         |  |
|-------------------------|--|
| <b>Use</b>              | <b>To dry coconut, chili and agro industrial products</b>  |
| <b>Capacity</b>         | <b>1 – 1.5 tonnes/day.</b><br><b>5000 nuts/batch for coconut</b>   |
| <b>Salient Features</b> | <b>Clean and hygienic drying.</b><br><b>200µm thick UV stabilized polyethylene as collector material</b><br><b>Hot air temperature up to 60°</b> |
| <b>Cost</b>             | <b>Rs. 1,30,000 (60f L * 12f B * 6f H)</b>   |

Commercialized by TNAU



## Greenhouse Operations

Commercial greenhouses typically rely on the sun to supply their lighting needs, but they are not designed to use the sun for heating. Instead, they rely on gas or oil heaters to maintain the temperatures necessary to grow plants in the colder months. Solar greenhouses, however, are designed to utilize solar energy for both heating and lighting. A gas or oil heater may serve as a back-up heater, or to increase carbon dioxide levels to induce higher plant growth.

## Livestock Operations

Many pig and poultry farms raise animals in enclosed buildings to control temperature and air quality in an effort to maintain animal health and growth. These facilities need to replace the indoor air regularly to remove moisture, toxic gases, odours, and dust. Heating this air, when necessary, requires large amounts of energy. With proper planning and design, solar air heaters can be incorporated into farm buildings to preheat incoming fresh air.

Solar energy is a huge source of renewable energy and the state is blessed with abundant of solar energy with 240 to 320 days of full sunshine in a year with daily radiation 4 - 7 kWh per m<sup>2</sup>. Solar energy incident on 1% of our land area at 2% net conversion efficiency can produce 6,00,000 MW of power and this energy is freely available at most places at no cost, pollution free. In this session, the presentation on the use of solar energy for Agro processing , by Tamil Nadu Energy Development Authority(TEDA) highlighted on the use of solar power for agro processing. It was noted that India spends around 17,80,000 KI/y or equivalent of F.O. for meeting 60% of thermal energy used in industries for processing the end product and about 5 million m<sup>2</sup> of solar collector for industrial processing and another 5 million m<sup>2</sup> for Agro industries could reduce the fuel consumption by 25%.

of thickness 75mm, silica sealant and EPDM rubber. Fresh air will be zig – zagged below the special “V” corrugated aluminium that the collector will deliver hot air in the range of 60 – 95 °C depending upon Solar radiation. Insulated metal duct will draw the Solar heated air through suitable blower with necessary controls and deliver it to the inlet points of the drier.

**SOLAR AIR HEATER**

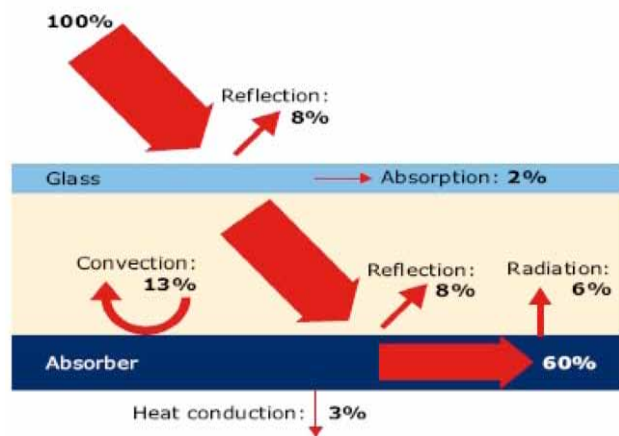

**Solar Water Pumps will directly impact:**

- Agriculture**
  - Improvement of the yield per unit of land/ water
  - Accelerating innovation and extension mechanism and ensure timely irrigation
- Energy**
  - Encouraging renewable energy generating facilities.
- Water**
  - Improvement in irrigation practices and reduction of water losses
  - Promotion of efficient water use by modernization of irrigation systems
  - Improved service delivery, participation of farmers and popularization of micro irrigation.

The solar panel will be installed on the separate South facing support frame of the factory. The Solar panel unit will be formed using aluminum extrusions; high absorption aluminium “V” corrugated absorber, 4mm thick toughened glass, mineral wool insulation

The areas of application of the solar power are mainly focussed towards Agriculture, Pharmaceutical, Leather Textiles, Ceramics, Chemical, Industrial Process heat, Minerals Latex rubber/mattres Paint-shop Laundry drying, Fabricated wet components drying, Heating in Oil and Gas production units etc. In the Agro processing industries solar energy plays an important role in Tea & Coffee Processing, drying spices like, Pepper, Turmeric, Garlic, Chilies, Coriander & Ginger, Grains like Pulses, Oil making units- pre-drying – copra, groundnut, cotton seed, gingelly, etc., Fruits and Vegetables, Fish – salted and dried, Small solar drier with SPV for rural job creation and value addition to product.



The Ministry of Non Renewable Energy (MNRE) assists the solar energy installations by providing assistance of 30% of the cost of the system subject to a maximum of Rs.2,400 per sq.m of collector area for commercial / institutional and industrial areas. Certain case studies on the Solar processing were presented during this session showed on the utilization of the solar power for Dal processing . India is a major producer and consumer of pulses. There are around 1400 pulse & processing units in the country and it offers employment in rural and sub urban mass. Due to the space constraint all pulse mills have shifted from open yard drying/heating method to conventional dryer heating method. The preferred fuel for processing pulses is diesel and in some cases coal (or) firewood. A conventional pulse processing unit uses around 15 -20 liter diesel/ hour to produce hot air of temperature around 65 deg C. Using a 7.5 kW blower, the hot air is blown through pulses spread in a 1 meter depth open trough (3 m X 3 m) with mesh at the lower side. The consumption of diesel/day in a typical pulses unit is around 60 - 90 liters. The major advantage of using the solar power helps to savings of diesel up to 60 -90 liters/ day depending upon the number of batches/ day. The quality of dal is also improved due to good level of solar heat aeration. There is an increase of 10% output from the dal than the conventional heated dal. This creates a premium for the product.

The case study presented in this session highlighted on the Solar Air Heating System installed in Theni District in a Dal Processing Industry for drying purpose which has 123 collectors with an area of 230sq.m. (89Nosx1.860mx1.009) and Solar Air Heating System installed in Thoothukudi District in an Industry for Copra drying process .



297 m<sup>2</sup> Solor air heating system at TI cycles in Ambatur Chennai



135 sq.mt TAFE



135 sq.m at M/s LARSEN & TOUBRO



135 sq.m at M/s LARSEN & TOUBRO



297 sq.m at Visteon Automotive systems India Pvt Ltd



Duct Connection and automation at Visteon Automotive Systems India Pvt. Ltd



A Solar PV Water Pumping System consists of SPV modules, Pump controller, AC/DC pump etc., The system does not have any Storage Battery since power generated is used directly then and there. The SPV array converts the solar energy into electricity which is used for running the motor pump set. The pumping system can draw water from the open well / bore well or stream / pond or canal. Ongoing Solar Pumping System Project in Tamil Nadu has 5 HP AC submersible pump with Solar module array of 4800 Wp which is suitable for open/shallow/bore wells of dia 6" with the total maximum dynamic head - 80M and water discharge of 82,000 litres/day from a total head of 50M. The project is taken up with contribution of 50% from NADP ,30% from MNRE and 20% as Beneficiary contribution.

### Solar Pumping System Basic set up

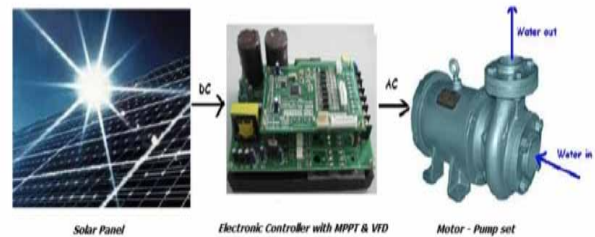

### 5 HP Surface mounted Solar Pump installed at Alamathy, Chennai





**5 HP AC Submersible Solar Pump installed at Alamathy, Chennai**



**10 HP Solar Pump installed at Pollachi, Coimbatore**





- » The potential for solar energy in Tamil Nadu for agriculture water pumps and heating and drying applications in post harvesting is acknowledged by various agencies. The cost effectiveness on using the solar power needs to be emphasised in relation to the consumption of the electricity and not specific to initial investment.
- » It is recommended that the roll out of a solar water pump scheme needs to be studied with regard to its constraints that would include the water table levels in districts, and the impact of solar water pumps on various crops, crop productivity, enhanced income through cash crop cultivation potential etc.
- » The contribution of water pumping scheme to the farmer's net income and also the agricultural productivity needs to be studied anecdotally.
- » The solar water pumping involves advanced and sophisticated technology, the roll out of such a scheme also needs to take into account the service aspects and the down times caused due to malfunctions.
- » The local ecosystem of the districts should be taken into consideration for the effective implementation. Cluster based approach for implementation of the solar projects needs to be piloted for the grass root level implementation.
- » The technical players and solution providers are to work in an integrated manner.
- » Huge savings that could incur to the electricity board on taking up the solar projects should be enlightened to the people.
- » Capacity building and the awareness campaign on the Solar policy of TN, needs to be given wide importance in the ensuing period.





## LIST OF PARTICIPANTS

| Sl.No. | Name & Designation  |
|--------|---|
| 1      | <b>Tmt. Santha Sheela Nair, I.A.S., (Retd.),</b><br>Vice-Chairman, State Planning Commission, Chennai.                                    |
| 2      | <b>Thiru S. Krishnan, I.A.S.,</b><br>Principal Secretary to Government, Planning and Development Department, Secretariat, Chennai.        |
| 3      | <b>Dr.K.Ramasamy</b><br>Member (Agri.), State Planning Commission and Vice-Chancellor,<br>Tamil Nadu Agricultural University, Coimbatore. |
| 4      | <b>Thiru M. Balaji, I.A.S.,</b><br>Member-Secretary, State Planning Commission, Chennai.  |
| 5      | <b>Thiru Rajesh Lakhoni, I.A.S.,</b><br>Secretary to Government, Energy Department, Secretariat, Chennai.                                 |
| 6      | <b>Thiru Sudeep Jain, I.A.S.,</b><br>Chairman and Managing Director, Tamil Nadu Energy Development Agency,<br>Chennai.                    |
| 7      | <b>Thiru Harish Chebra,</b><br>Additional Director of Agriculture, Chennai.   |
| 8      | <b>Thiru K. Megraj,</b><br>Additional Director of Rural Development, Chennai  |
| 9      | <b>Thiru W. Duke Christopher,</b><br>Deputy General Manager, Tamil Nadu Energy Development Agency, Chennai.                               |
| 10     | <b>Thiru M. Paranthaman,</b><br>Deputy Senior Manager/ST, Tamil Nadu Energy Development Agency, Chennai.                                  |
| 11     | <b>Thiru Ravikumar Kandasamy,</b><br>Deputy Director, Mahatma Gandhi Institute of Rural Industrialisation, Mumbai.                        |
| 12     | <b>Thiru P.S.Karunakaran,</b><br>Deputy Director of Agriculture (Marketing), Directorate of Agriculture ,<br>Chepauk, Chennai.            |
| 13     | <b>Tmt. Shanthi Sundar Raman,</b><br>Asst. Executive Engineer, O/o. Chief Engineer, Agrl. Engineering Department, Chennai                 |
| 14     | <b>Thiru P.Ravichandran,</b><br>Assistant Engineer (Agrl. Engineering), O/o. Chief Engineer, Agrl. Engineering<br>Department, Chennai     |

|    |   |
|----|---|
| 15 | <b>Dr. A. A.Nambiani,</b><br>Director, Climate Change Programme, M.S.Swaminathan Research Foundation, Chennai.                        |
| 16 | <b>Dr.Ummesh Patnair,</b><br>Principal Scientist, Climate Change Programme,<br>M.S. Swaminathan Research Foundation, Chennai-600 113. |
| 17 | <b>Thiru Ravi Karamchetty,</b><br>Managing Director, Sun Edison, Chennai.   |
| 18 | <b>Thiru R. Rangarajan Ramaswamy</b><br>Director (Science & Training)Grundfos Pumps India Pvt. Limited, Chennai.                      |
| 19 | <b>Thiru M. Karthik,</b><br>Associate Manager, Sun Edison, Chennai.   |
| 20 | <b>Thiru Vinod Solomon,</b><br>Assistant Secretary, The Southern India Chamber of Commerce Industry, Chennai-600 108.                 |
| 21 | <b>Thiru Vineeth Vijayaraghavan,</b><br>Editor, Panchabuta, Chennai.  |
| 22 | <b>Ms M. Naga Nithikha,</b><br>Project Coordinator, Citizen Customer and Civic Action Group, Chennai.                                 |
| 23 | <b>Thiru Vishnu</b><br>Citizen Customer and Civic Action Group, Chennai.  |
| 24 | <b>Thiru P.Selvarajan</b><br>Head of Division (DP), State Planing Commission, Chennai   |
| 25 | <b>Thiru Dr. K.R. Jahanmohan</b><br>Head of Division (AAP), State Planing Commission, Chennai   |
| 26 | <b>Thiru M. Kumaresan</b><br>Head of Division, Education and Employment Division,SPC<br>State Planing Commission, Chennai             |
| 27 | <b>Ms M.S. Navaneetham</b><br>Head of Division , Health and Social Welfare Division,SPC<br>State Planing Commission, Chennai          |
| 28 | <b>Thiru Dr. Sugato Dutt, I.F.S.,</b><br>Head of Division (LU), State Planing Commission, Chennai                                     |



